

callie neylan / *e* neylan@umbc.edu / *t* @neylano

Beautiful Interactions

Codifying Aesthetics
In Interaction Design

...if it isn't beautiful, it probably
shouldn't be at all. – *Yves Béhar*

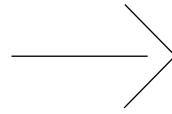

humans need beauty for survival.

we have evolved to love beautiful things.

experiencing beauty

visceral

how things look, feel, and sound. innate, instinctive.

behavioral

how things function. learned.

reflective

what things mean. infused through experience.

exploiting beauty

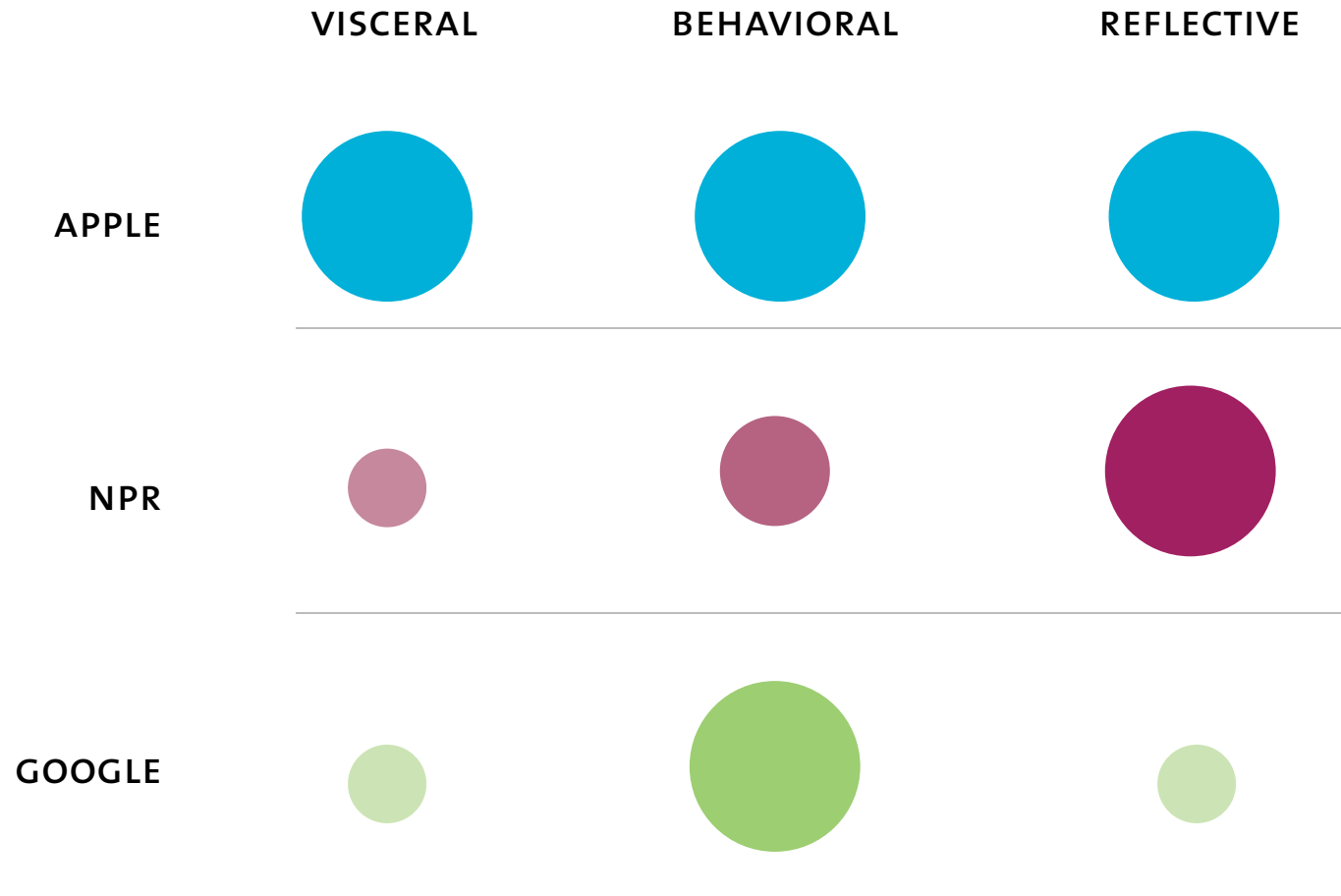

I am of the opinion that it is possible to develop an art largely on the basis of mathematical thinking. – *Max Bill*

aesthetics via the five senses

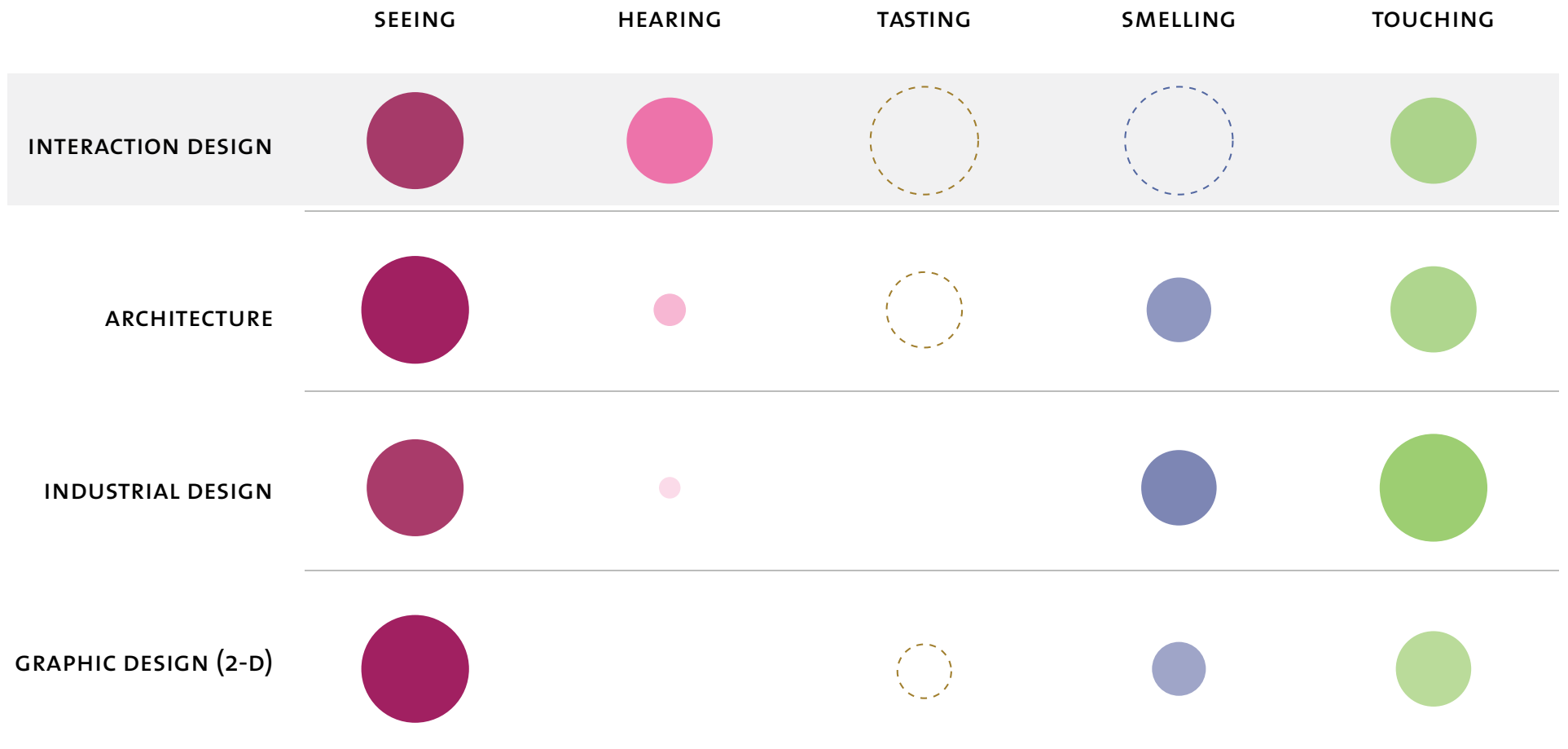

the fibonacci sequence + the golden mean

0, 1, 1, 2, 3, 5, 8, 13, 21, 34, 55, 89, 144, ϕ

1 : 1.618 or ϕ

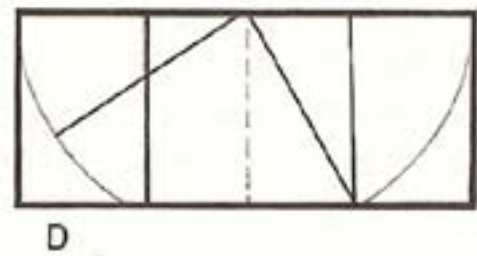
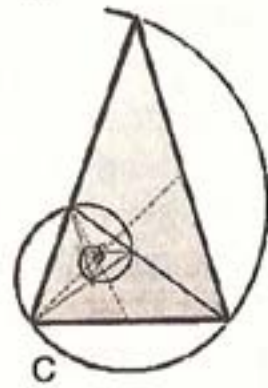
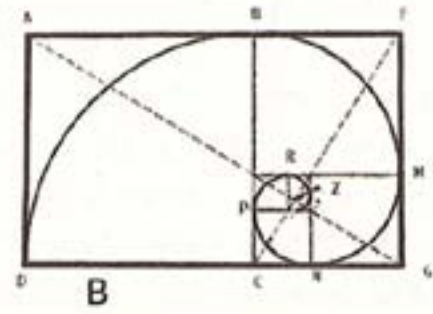
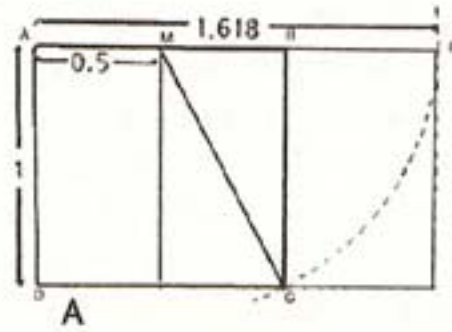



What's happening?

Timeline @Mentions Retweets Searches Lists

Tweets mentioning @stop

 **Coley Wopperer**
@stop @zhanna Correction: Three-PERSON design team.
from Potrero, San Francisco
33 minutes ago

 **ozanilbey** Ozan İlbey Yılmaz
Dear #NewTwitter, "good proportion" is one of the main design principles. Remember? @stop @design
1 hour ago ☆ Favorite ↻ Retweet ↩ Reply

 **ashleyv** Ashley Veselka
Right? LOVE #newtwitter! Great job @stop @Zhanna RT @jonstovall: man, twitter. you really know how to do webz
1 hour ago

 **Zhanna** Zhanna Shamis
@goldman @stop right on!
from SoMa, San Francisco
1 hour ago

 **ozanilbey** Ozan İlbey Yılmaz
Dear #NewTwitter, "good proportion" is one of the main design principles. Remember? @stop @design
1 hour ago via web ☆ Favorite ↻ Retweet ↩ Reply

Mentioned in this tweet

 **design** Twitter Design
Tweets from the Twitter Design Team.

Replies to this Tweet

 **ozansener** ozansener
@ozanilbey ya o proportion bazen ise yariyo :p ama gerektiğinde buyumesi daha guzel olurdu.
from Princeton North, NJ
1 hour ago

Tweets tagged with #NewTwitter

what, then, is the temporal equivalent of the golden mean?

temporal beauty

pink noise

Pink noise is a type of signal that contains all of the sound frequencies that fall within the range of human hearing — from the lowest pitches that a person can hear to the highest tones. It is a filtration of white noise.

The presence of pink noise is the ultimate evidence of a beautiful interaction.

ocean surf a là pink noise

biomimicry + relationships.

modeling interactions after beautiful relationships.



the aesthetics of interaction design are universal, multisensory, and based on mathematics + biomimicry.

interaction designers are mixers of an aesthetic equalizer.

Thank you.

callie neylan / e neylan@umbc.edu / t @neylano